

Hold down clamps

Hold down clamps, machine table clamps



The BESSEY® machine table clamp offering has a variety of handle and configuration options available for challenging clamping situations.

1 Traditional clamping arm and handle

The BSG family of clamps have a lever handle with a ratcheting mechanism for controlled, fast and vibration proof clamping. Ideal for machines equipped with "T" slots.

2 Lever handles

Lever handles offer greater set-up speed and enhanced resistance to vibration than other clamping handle styles.



Hold down table clamp

Vibration proof, ratchet action for rapid clamping. Pressure pad self-adjusts on the workpiece. Drop forged steel clamping arm. Mounting hole accepts 5/8" bolts.

	Max Clamping Height	Throat Depth	Clamping Force	Rail Profile	Fixing Hole	Approx. Weight
BS3N	8"	4.75"	1200 lbs	0.87" x 0.41"	0.51"	3.42 lbs
BS4N	8"	4.75"	1650 lbs	1.10" x 0.43"	0.65"	5.84 lbs
2400 HD-10	9.5"	5.5"	2220 lbs	1.18" x 0.59"	0.65"	7.80 lbs
BS6N	20"	5.5"	2220 lbs	1.18" x 0.59"	0.65"	8.82 lbs



Hold down table clamps, BSG

For fastening to tables and other equipment. Long life due to heat-resistant pressure plate with sintered steel insert, which can be tilted up to 35°. Mounting hole accepts 5/8" bolts.

	Max Clamping Height	Throat Depth	Clamping Force	Rail Profile	Fixing Hole	Approx. Weight
BSG21-14	8.25"	5.5"	2650 lbs	1.18" x 0.59"	0.65"	7.10 lbs



Hold down clamps

Hold down clamps, machine table clamps



Table of dimensions

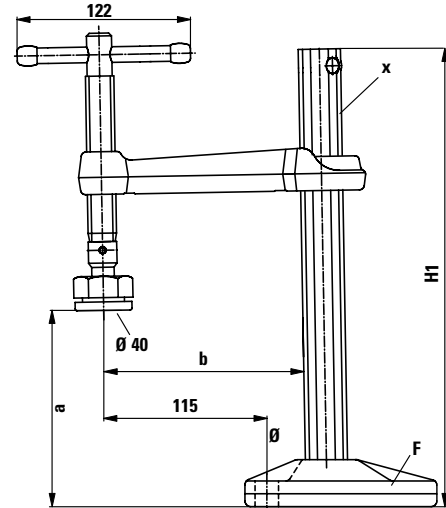
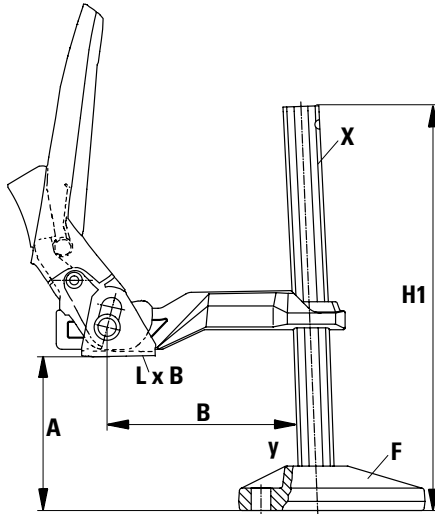

BSN

BSG

	Opening Max	Throat Depth	Base Height	Pressure Plate Dimensions	Foot Length	Foot Width	Foot Height	Foot Distance to the rail	Rail Profile	Fixing Hole	Clamping Force
	A	B	H1	L x B	F	F	F	F to Y	X	Ø	
BS3N	200mm/8.00"	120mm/4.75"	260mm/10.24"	42x25mm/1.65 x 0.98"	100mm/3.94"	38mm/1.50"	25mm/0.98"	32mm/1.26"	19.5x9.5mm/0.87x0.41"	10.5mm/0.51"	1200 lbs
BS4N	200mm/8.00"	120mm/4.75"	270mm/10.63"	48x31mm/1.89 x 1.22"	135mm/5.31"	49mm/1.93"	33mm/1.30"	42mm/1.65"	28x11mm/1.10 x 0.43"	16.5mm/0.65"	1650 lbs
2400HD-10	240mm/9.50"	140mm/5.50"	320mm/12.60"	48x31mm/1.89 x 1.22"	135mm/5.31"	49mm/1.93"	33mm/1.30"	42mm/1.65"	30x15mm/1.18 x 0.59"	16.5mm/0.65"	2220 lbs
BS6N	500mm/20.00"	140mm/5.50"	580mm/22.83"	48x31mm/1.89 x 1.22"	135mm/5.31"	49mm/1.93"	33mm/1.30"	42mm/1.65"	30x15mm/1.18 x 0.59"	16.5mm/0.65"	2220 lbs
BSG21-14	210mm/8.25"	140mm/5.50"	322mm/12.68"	Ø 40mm/1.57"	135mm/5.31"	48mm/1.89"	33mm/1.30"	42mm/1.65"	30x15mm/1.18 x 0.59"	16.5mm/0.65"	2650 lbs

Note: Clamping force calculated at a height of 2-3" on a solid all-steel welding table platform

Jig & fixture clamp, FC

A full rotation of 360° for easy work-piece removal. The pressure plate swivels up to 35° and the bushing O/D is 1¹³/₁₆", and can fit a table thickness of 1/2" to 1 1/2". Bushing can be set to be freely rotating, fixed or quick release position by adjusting or removing bottom plate.



	Clamping Capacity	Throat Depth	Clamping Force	Approx. Weight
FC24-8 3100459	8"	5 1/2"	2660 lbs	6.45 lbs

Inner/outer bushing set for FC24